

# COMBIMASS<sup>®</sup>

Technical Data Analyzer Station  
GA-s hybrid eco CH<sub>4</sub>  
for monitoring of gas quality



## GAS ANALYZER STATION COMBIMASS® GA-s hybrid

For decades now, Binder has been supplying leading plant manufacturers with innovative systems for industrial gas flow measurement. In the last few years, the demand for reliable, precise and cost-effective measuring systems for biogas, sewage gas and landfill gas has increased significantly.

Modern **anaerobic digestion (AD) plants** cannot meet commercial and environmental requirements without appropriate measuring and analysis technique. Analyzers are used to determine gas composition of each single digester, to monitor the operation of H<sub>2</sub>S-filter and gas-cleaning in front of CHP units.

In **sewage treatment plants** analyzers are used to monitor the H<sub>2</sub>S-filter upstream of the CHP units respectively monitor the gas quality directly after the digester. Compared to AD plants the gas quality doesn't change so much in time (exception: digestion plants with co-fermentation).

In **landfills** the analyzers are used for long-time monitoring of single wells or gas quality in collector pipes. In older landfills often methane or propane must be mixed with the landfill gas of poor quality to make energetic use in CHP units possible.

The engine settings in the CHP unit can be based on methane concentration, e.g. the spark advance can be adjusted to achieve maximum electrical efficiency and lowest emissions. Even if a gas storage tank is operated between the digester and the CHP, methane concentration can change over time, so fixed settings in the CHP will lead to suboptimal operation. Precise and stable analysis of the CH<sub>4</sub>-concentration as well as the use of this information to control the CHP can improve the economic situation of the plant, because only a small portion of the energy in the gas can be converted to electrical energy. A large part is converted to heat.

The basic analyzer station COMBIMASS GA-s hybrid eco CH<sub>4</sub> consists of a ventilated cabinet for indoor installation, such as in the CHP-room, fixed at a fixed sampling frequency. The cabinet contains a gas pump, a methane gas cell (0-100 Vol.-%) as well as necessary number of valves for analysis and purging of gas modules. One 4-20mA analog output transmits the data to the customer's PLC. Additionally a digital output for transmission of a common alarm is available.

A further input for calibration gas allows the check and recalibration of the gas modules at site by Binder service employees or an authorized service company. Maintenance is very easy: the filter and other small service parts can be replaced at site by the operator. The gas module should be checked every 12 months at the manufacturer and refurbished if necessary. New or refurbished gas modules can be provided, so data transmission is uninterrupted. The replacement of the gas modules takes less than 2 minutes and can be done by the operator.

# TECHNICAL DATA ANALYZER STATION GA-s hybrid eco

## MAIN COMPONENTS ANALYZER CABINET

- 1 plastic cabinet for wall mounting: 300x400x200, IP22, 24 VDC, for indoor- installation in a protected environment (+5 to + 40°C, non-corrosive), monitored for LEL by separate means, all connections on the cabinet are prepared for plastic hoses
- 1 CH<sub>4</sub> gas module of the hybrid-series with a NDIR-cell, operation range: 0-100 Vol.-%
- 3 valves NC (1xgas, 1x purging air, 1x calibration gas)
- 1 biogas pump
- 1 manual calibration function (using a service-software)
- 1 ventilation system with an indirect leakage monitoring
- hardware and software for measuring function, purging of gas modules after each sampling
- hardware and software for pressure and temperature compensation of the signal
- monitoring of min./max. ambient temperature and pressure
- transmission of data via one analog signal 4-20 mA (or Modbus RTU)
- transmission of a common alarm via a digital output (or single alarms using Modbus RTU)

## FURTHER OPTIONS of hybrid eco-series

- a second gas sampling point with an additional valve NC and transmission of data and single alarms using Modbus RTU
- all connections on the cabinet are prepared for stainless steel tubes (usually in sewage treatment plants)
- external power supply box 230 VAC/24 VDC (for the analyzer cabinet, which operates at 24 VDC for safety reasons)
- further gas modules O<sub>2</sub> 0-25 Vol.-% or H<sub>2</sub>S -50 (200, 2.000) ppm \*
- 1 gas cooler with hardware-extension DTG-GK, a second pump and one valve NO (in addition to the NC valve in front of the H<sub>2</sub>S-module), if methane shall be analyzed continuously
- read & transmit an analog signal of a biogas flow meter of COMBIMASS® series
- further components for gas pre-treatment, e.g. coalescence filter of several sizes, stainless steel flame arrestor with ATEX-approval etc. mounted on DIN-rail plates
- heating/ cooling equipment for outdoor installation of the analyzer cabinet\*

\* Some of the options require additional hardware components like further gas pumps, a bigger cabinet or can lead to changes in type of data transmission (if more than 3 signals shall be transferred Modbus RTU is required).

## TECHNICAL DATA

No. of sampling points	Standard: 1 (can be expanded up to 2)
Ambient conditions	Indoors, ventilated and monitored for LEL, +5 to +40°C, humidity < 80% rel., non-corrosive
Gas properties	+5 to +40°C, 10 - 90% rel. humidity
Protection class	IP22
Transmission of data and alarms	1-3 pcs. 4-20 mA analog outputs & 1 digital output or Modbus RTU
Flow capacity gas pump	500 ml/min (during gas sampling)
Connection	Plastic hoses OD Ø 6 mm/ ID Ø 4 mm (recommendation: Norprene Ø 6.4 mm/ Ø 3.2 mm; option PVC or Tygone Ø 6.0 mm/ Ø 4.0 mm), option stainless steel Ø 6.0 mm/ Ø 4.0 mm)

## DESIGN ANALYZER CABINET AND GAS FLOW SCHEME

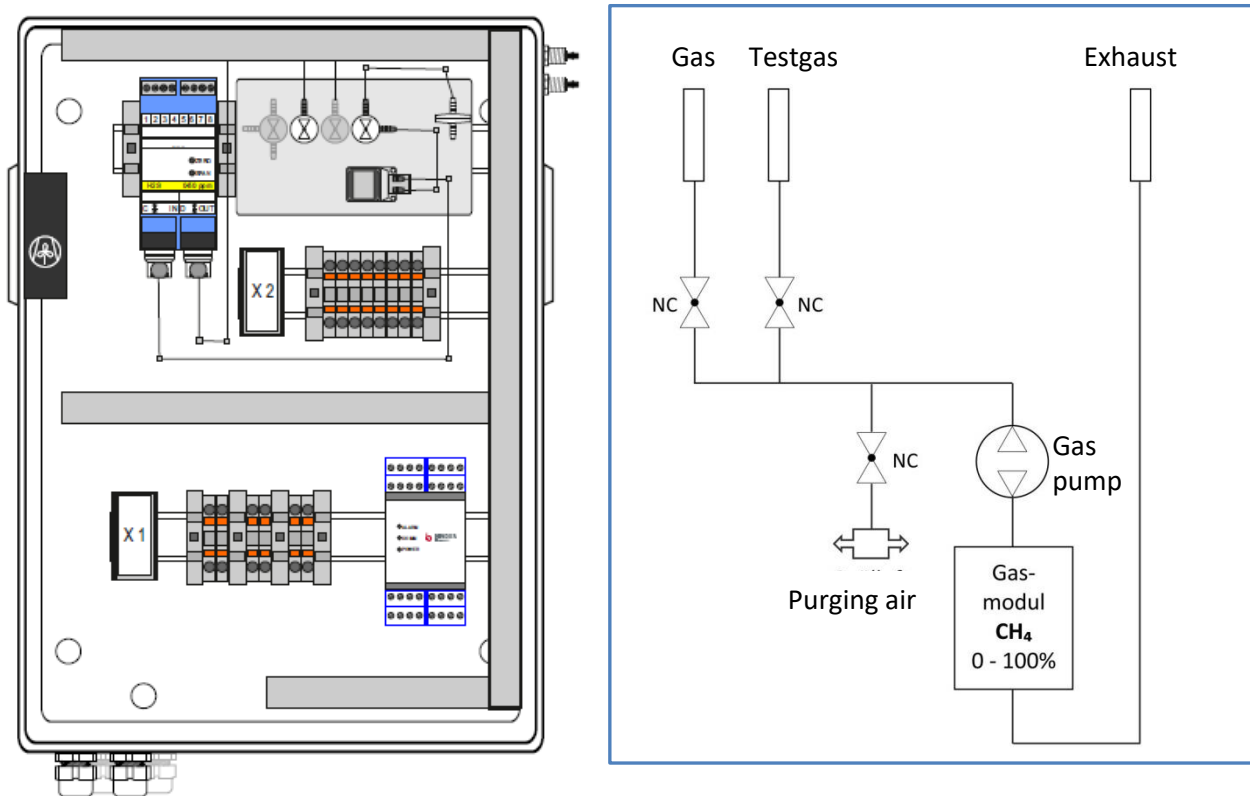

## COMBIMASS® GA-s hybrid eco CH<sub>4</sub>

Gas flow scheme for an analyzer station with continuous analysis of methane (option):

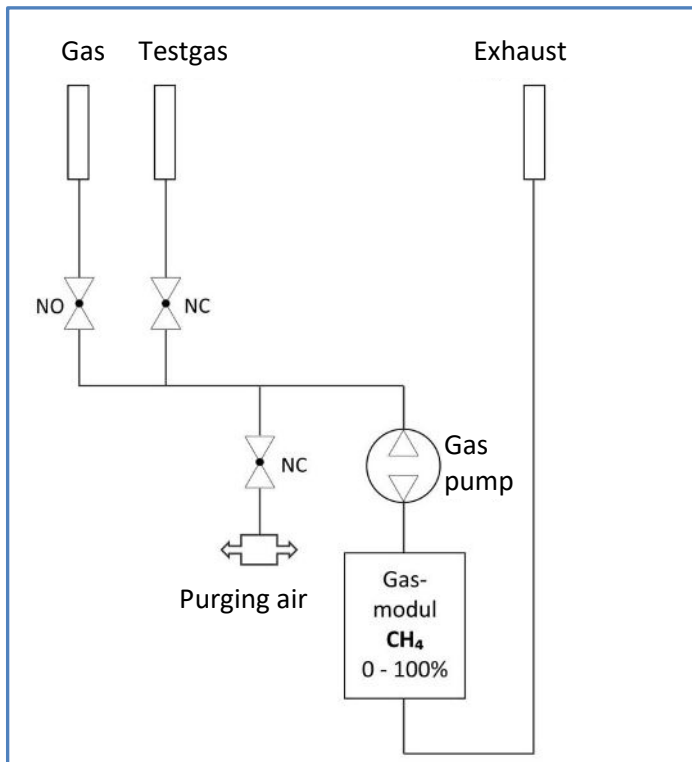

### IMPRINT

BINDER GmbH  
Buchbrunnenweg 18  
89081 Ulm, Germany  
Tel. +49 731 18998-0  
Fax +49 731 18998-88

info@bindergroup.info  
www.bindergroup.info

BIDE-M-D- Datenblatt COMBIMASS GA-s hybrid  
eco CH<sub>4</sub>-EN-R02